

Electrolytic Nickel

Electrolytic nickel is an indispensable, important metal that supports Japan's cutting edge technologies including electronics, chemical engineering, food engineering, energy technology, aerospace industry, and, especially its semiconductor industry, as well as special steels. **Sumitomo Metal Mining Co., Ltd.** (SMM) is the only electrolytic nickel producer in Japan. Presently, SMM continues providing a stable supply of Electrolytic Nickel in order to respond the needs of each industry.

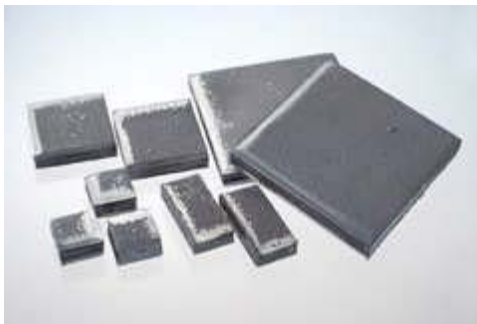

Quality characteristics

(Unit: %)

Ni	Co	Fe	Cu	Mn	Pb	C	S	Si	Zn	Al
≥ 99.98	≤ 0.01	≤ 0.005	≤ 0.002	≤ 0.001	≤ 0.001	≤ 0.01	≤ 0.001	≤ 0.0005	≤ 0.0005	≤ 0.0001

- Various sizes from 25 mm X 25 mm to 150 mm X 1000 mm

Packaging

- Comes in various types of packages, from drums containing 500 kg to full plate.



Full Plates



500kg drums on pallet

Electrolytic Nickel

Details in Packing

• Full Plates

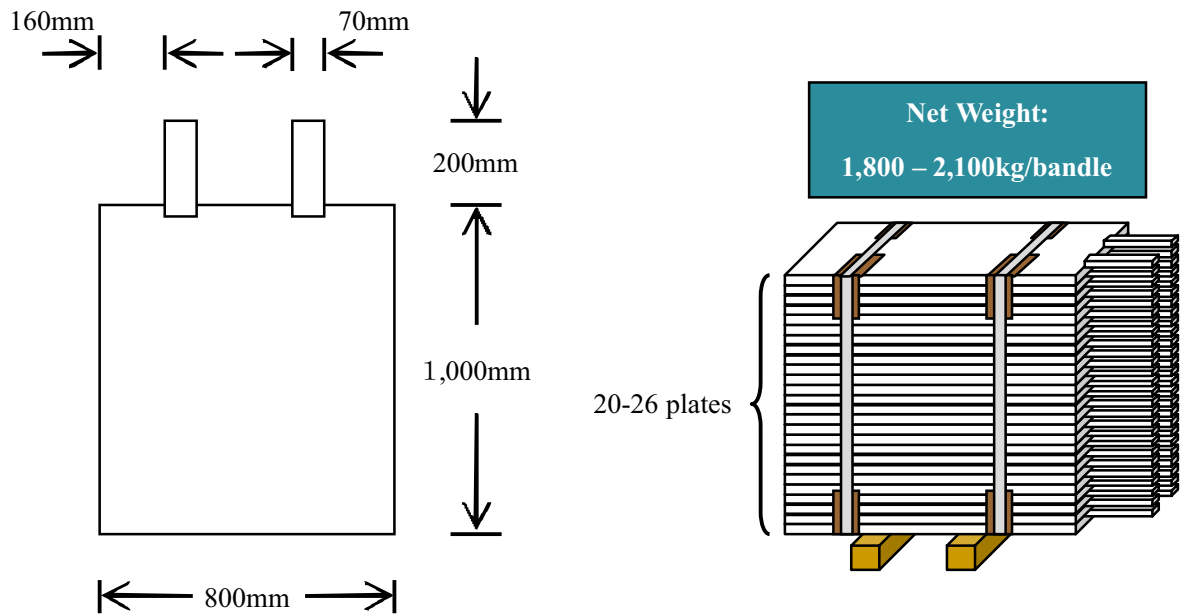

• Drums

